

TS5A22364 0.65-Ω Dual SPDT Analog Switches With Negative Signaling Capability

1 Features

- Specified Break-Before-Make Switching
- Negative Signaling Capability: Maximum Swing from -2.75 V to 2.75 V ($V_{CC} = 2.75\text{ V}$)
- Internal Shunt Switch Prevents Audible Click-and-Pop When Switching Between Two Sources
- Low ON-State Resistance ($0.65\ \Omega$ Typical)
- Low Charge Injection
- Excellent ON-State Resistance Matching
- 2.3-V to 5.5-V Power Supply (V_{CC})
- Latch-Up Performance Exceeds 100 mA Per JESD 78, Class II
- ESD Performance Tested Per JESD 22
 - 2500-V Human-Body Model (A114-B, Class II)
 - 1500-V Charged-Device Model (C101)
 - 200-V Machine Model (A115-A)

2 Applications

- Cell Phones
- PDAs
- Portable Instrumentation
- Audio Routing
- Medical Imaging

3 Description

The TS5A22364 is a bidirectional, 2-channel, single-pole double-throw (SPDT) analog switch designed to operate from 2.3 V to 5.5 V. The device features negative signal capability that allows signals below ground to pass through the switch without distortion. Additionally, the TS5A22364 includes an internal shunt switch, which automatically discharges any capacitance at the NC or NO terminals when they are unconnected to COM. This reduces the audible click/pop noise when switching between two sources. The break-before-make feature prevents signal distortion during the transferring of a signal from one path to another. Low ON-state resistance, excellent channel-to-channel ON-state resistance matching, and minimal total harmonic distortion (THD) performance are ideal for audio applications. The 3.00-mm x 3.00-mm DRC package is also available as a nonmagnetic package for medical imaging applications.

Device Information (1)

PART NUMBER	PACKAGE	BODY SIZE (NOM)
TS5A22364	VSON (10)	3.00 mm x 3.00 mm
	DSBGA (10)	1.90 mm x 1.40 mm
	VSSOP (10)	3.00 mm x 3.00 mm

(1) For all available packages, see the orderable addendum at the end of the data sheet.

Typical Application Schematic

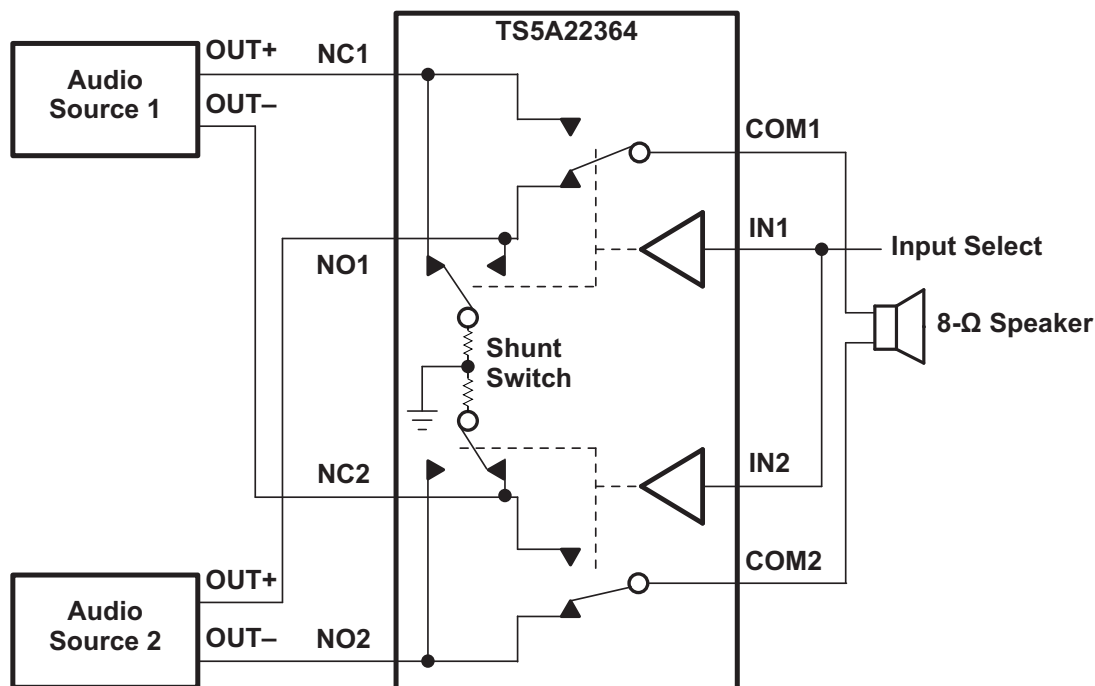

Table of Contents

1 Features 1 2 Applications 1 3 Description 1 4 Revision History 2 5 Pin Configuration and Functions 3 6 Specifications 4 6.1 Absolute Maximum Ratings 4 6.2 ESD Ratings 4 6.3 Recommended Operating Conditions 4 6.4 Thermal Information 5 6.5 Electrical Characteristics for 2.5-V Supply 5 6.6 Electrical Characteristics for 3.3-V Supply 6 6.7 Electrical Characteristics for 5-V Supply 8 6.8 Typical Characteristics 9 7 Parameter Measurement Information 11 8 Detailed Description 15 8.1 Overview 15	8.2 Functional Block Diagram 15 8.3 Feature Description 16 8.4 Device Functional Modes 16 9 Application and Implementation 17 9.1 Application Information 17 9.2 Typical Application 17 10 Power Supply Recommendations 19 11 Layout 19 11.1 Layout Guidelines 19 11.2 Layout Example 19 12 Device and Documentation Support 20 12.1 Community Resources 20 12.2 Trademarks 20 12.3 Electrostatic Discharge Caution 20 12.4 Glossary 20 13 Mechanical, Packaging, and Orderable Information 20
--	--

4 Revision History

NOTE: Page numbers for previous revisions may differ from page numbers in the current version.

Changes from Revision F (June 2015) to Revision G	Page
<ul style="list-style-type: none"> • Changed C_L TEST CONDITION value for all THD PARAMETERS from 15 pf to 35 pf. 7 	7
Changes from Revision E (May 2013) to Revision F	Page
<ul style="list-style-type: none"> • Added <i>Pin Configuration and Functions</i> section, <i>ESD Ratings</i> table, <i>Recommended Operating Conditions</i> table, <i>Feature Description</i> section, <i>Device Functional Modes</i>, <i>Application and Implementation</i> section, <i>Power Supply Recommendations</i> section, <i>Layout</i> section, <i>Device and Documentation Support</i> section, and <i>Mechanical, Packaging, and Orderable Information</i> section 1 • Split the TS5A22364 and TS5A22362 into separate datasheets and added verbiage to clarify the operation of the shunt resistor. 1 • Changed the max R_{on} spec from 1.04 Ω to 1.30 Ω at 2.7 V V_{CC} across full T_A. 5 	1 1 5
Changes from Revision D (November 2011) to Revision E	Page
<ul style="list-style-type: none"> • Added <i>Absolute Maximum Ratings</i> textnote 4 	4
Changes from Revision C (April 2010) to Revision D	Page
<ul style="list-style-type: none"> • Added Medical Imaging to <i>Applications</i> 1 	1

5 Pin Configuration and Functions

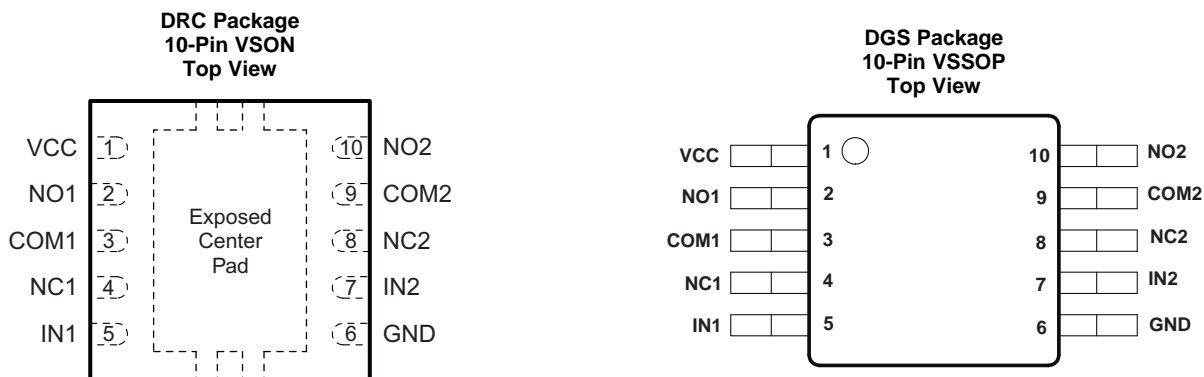

*The exposed center pad, if used, must be connected as a secondary GND or left electrically open.

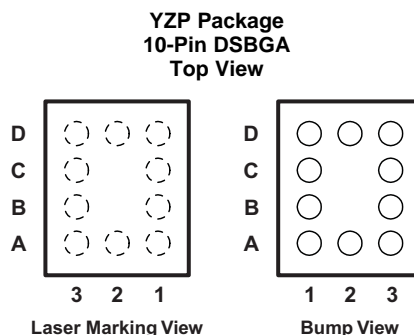

Pin Functions

NAME	PIN		TYPE	DESCRIPTION
	DRC / DGS	YZP		
VCC	1	A2	—	Power Supply
NO1	2	A3	I/O	Normally Open (NO) signal path, Switch 1
COM1	3	B3	I/O	Common signal path, Switch 1
NC1	4	C3	I/O	Normally Closed (NC) signal path, Switch 1
IN1	5	D3	I	Digital control pin to connect COM1 to NO1, Switch 1
GND	6	D2	—	Ground
IN2	7	D1	I	Digital control pin to connect COM2 to NO2, Switch 2
NC2	8	C1	I/O	Normally Closed (NC) signal path, Switch 2
COM2	9	B1	I/O	Common signal path, Switch 2
NO2	10	A1	I/O	Normally Open (NO) signal Path, Switch 2

6 Specifications

6.1 Absolute Maximum Ratings

 over operating free-air temperature range (unless otherwise noted) ⁽¹⁾ ⁽²⁾

		MIN	MAX	UNIT
V_{CC}	Supply voltage ⁽³⁾	-0.5	6	V
V_{NC} V_{NO} V_{COM}	Analog voltage ⁽³⁾ ⁽⁴⁾ ⁽⁵⁾	$V_{CC} - 6$	$V_{CC} + 0.5$	V
$I_{I/OK}$	Analog port diode current $V_{NC}, V_{NO}, V_{COM} < 0$ or $V_{NC}, V_{NO}, V_{COM} > V_{CC}$	-50	50	mA
I_{NC} I_{NO} I_{COM}	ON-state switch current ON-state peak switch current ⁽⁶⁾	-150 -300	150 300	mA
I_{RSH}	OFF-state switch Shunt Resistor current	-20	20	
I_{NC} ⁽³⁾ ⁽⁷⁾ ⁽⁸⁾ I_{NO} ⁽³⁾ ⁽⁷⁾ ⁽⁸⁾ I_{COM} ⁽³⁾ ⁽⁷⁾ ⁽⁸⁾	ON-state switch current ON-state peak switch current ⁽⁶⁾	-350 -500	350 500	mA
V_{IN}	Digital input voltage range	-0.5	6.5	
I_{IK}	Digital input clamp current ⁽³⁾ ⁽⁴⁾ $V_I < 0$	-50	50	mA
I_{CC} I_{GND}	Continuous current through V_{CC} or GND	-100	100	mA
T_{stg}	Storage temperature	-65	150	°C

- (1) Stresses beyond those listed under *Absolute Maximum Ratings* may cause permanent damage to the device. These are stress ratings only, which do not imply functional operation of the device at these or any other conditions beyond those indicated under *Recommended Operating Conditions*. Exposure to absolute-maximum-rated conditions for extended periods may affect device reliability.
- (2) The algebraic convention, whereby the most negative value is a minimum and the most positive value is a maximum.
- (3) All voltages are with respect to ground, unless otherwise specified.
- (4) The input and output voltage ratings may be exceeded if the input and output clamp-current ratings are observed.
- (5) This value is limited to 5.5 V maximum.
- (6) Pulse at 1-ms duration < 10% duty cycle.
- (7) $V_{CC} = 3.0$ V to 5.0 V, $T_A = -40$ °C to 85°C.
- (8) For YZP package only.

6.2 ESD Ratings

		VALUE	UNIT
$V_{(ESD)}$	Electrostatic discharge		
	Human-body model (HBM), per ANSI/ESDA/JEDEC JS-001 ⁽¹⁾	±2500	V
Charged-device model (CDM), per JEDEC specification JESD22-C101 ⁽²⁾	±1500		

- (1) JEDEC document JEP155 states that 500-V HBM allows safe manufacturing with a standard ESD control process. Manufacturing with less than 500-V HBM is possible with the necessary precautions.
- (2) JEDEC document JEP157 states that 250-V CDM allows safe manufacturing with a standard ESD control process. Manufacturing with less than 250-V CDM is possible with the necessary precautions.

6.3 Recommended Operating Conditions

over operating free-air temperature range (unless otherwise noted)

		MIN	MAX	UNIT
V_{CC}	Supply voltage	2.3	5.5	V
V_{NC} V_{NO} V_{COM}	Signal path voltage	$V_{CC} - 5.5$	V_{CC}	V
V_{IN}	Digital control	GND	V_{CC}	V

6.4 Thermal Information

THERMAL METRIC ⁽¹⁾		TS5A22364			UNIT
		DGS (VSSOP)	DRC (VSON)	YZP (DSBGA)	
		10 PINS	10 PINS	10 PINS	
R _{θJA}	Junction-to-ambient thermal resistance	163.3	44.3	90.9	°C/W
R _{θJC(top)}	Junction-to-case (top) thermal resistance	56.4	70.1	0.3	°C/W
R _{θJB}	Junction-to-board thermal resistance	83.1	19.3	8.3	°C/W
ψ _{JT}	Junction-to-top characterization parameter	6.8	2.0	3.2	°C/W
ψ _{JB}	Junction-to-board characterization parameter	81.8	19.4	8.3	°C/W
R _{θJC(bot)}	Junction-to-case (bottom) thermal resistance	N/A	6.2	N/A	°C/W

(1) For more information about traditional and new thermal metrics, see the *Semiconductor and IC Package Thermal Metrics* application report, [SPRA953](#).

6.5 Electrical Characteristics for 2.5-V Supply

V_{CC} = 2.3 V to 2.7 V, T_A = –40°C to 85°C (unless otherwise noted) ⁽¹⁾

PARAMETER		TEST CONDITIONS		T _A	V _{CC}	MIN	TYP	MAX	UNIT
ANALOG SWITCH									
V _{COM} , V _{NO} , V _{NC}	Analog signal range					V _{CC} – 5.5		V _{CC}	V
R _{on}	ON-state resistance	V _{NC} or V _{NO} = V _{CC} , 1.5 V, V _{CC} – 5.5 V I _{COM} = –100 mA,	COM to NO or NC, see Figure 13	25°C	2.7 V	0.65	0.94		Ω
				Full		1.3			
ΔR _{on}	ON-state resistance match between channels	V _{NC} or V _{NO} = 1.5 V, I _{COM} = –100 mA,	COM to NO or NC, see Figure 13	25°C	2.7 V	0.023	0.11		Ω
				Full		0.15			
R _{on(flat)}	ON-state resistance flatness	V _{NC} or V _{NO} = V _{CC} , 1.5 V, V _{CC} – 5.5 V I _{COM} = –100 mA,	COM to NO or NC, see Figure 13	25°C	2.7 V	0.18	0.46		Ω
				Full		0.5			
R _{SH}	Shunt switch resistance	I _{NO} or I _{NC} = 10 mA		Full	2.7 V		25	50	Ω
I _{COM(ON)}	COM ON leakage current	V _{NC} and V _{NO} = Floating, V _{COM} = V _{CC} , V _{CC} – 5.5 V,	See Figure 15	25°C	2.7 V	–50		50	nA
				Full		–375	375		
DIGITAL CONTROL INPUTS (IN) ⁽²⁾									
V _{IH}	Input logic high			Full		1.4		5.5	V
V _{IL}	Input logic low						0.6		
I _{IH} , I _{IL}	Input leakage current	V _{IN} = V _{CC} or 0		25°C	2.7 V	–250		250	nA
				Full		–250	250		

(1) The algebraic convention, whereby the most negative value is a minimum and the most positive value is a maximum

(2) All unused digital inputs of the device must be held at V_{CC} or GND to ensure proper device operation. Floating digital inputs will cause excessive current consumption. Refer to the TI application report, *Implications of Slow or Floating CMOS Inputs*, [SCBA004](#).

Electrical Characteristics for 2.5-V Supply (continued)
 $V_{CC} = 2.3 \text{ V to } 2.7 \text{ V}$, $T_A = -40^\circ\text{C to } 85^\circ\text{C}$ (unless otherwise noted) ⁽¹⁾

PARAMETER	TEST CONDITIONS	T_A	V_{CC}	MIN	TYP	MAX	UNIT	
DYNAMIC								
t_{ON}	Turnon time	$V_{COM} = V_{CC}$, $R_L = 300 \Omega$,	$C_L = 35 \text{ pF}$, see Figure 17	25°C	2.5 V	44	80	ns
				Full	2.3 V to 2.7 V		120	
t_{OFF}	Turnoff time	$V_{COM} = V_{CC}$, $R_L = 300 \Omega$,	$C_L = 35 \text{ pF}$, see Figure 17	25°C	2.5 V	22	70	ns
				Full	2.3 V to 2.7 V		70	
t_{BBM}	Break-before-make time	See Figure 18	25°C	2.5 V	1	7	ns	
Q_C	Charge injection	$V_{GEN} = 0$, $R_{GEN} = 0$	$C_L = 1 \text{ nF}$, see Figure 22	25°C	2.5 V	150	pC	
$C_{COM(ON)}$	NC, NO, COM ON capacitance	$V_{COM} = V_{CC}$ or GND, Switch ON, $f = 10 \text{ MHz}$	See Figure 16	25°C	2.5 V	370	pF	
C_I	Digital input capacitance	$V_{IN} = V_{CC}$ or GND	See Figure 16	25°C	2.5 V	2.6	pF	
BW	Bandwidth	$R_L = 50 \Omega$, -3 dB		25°C	2.5 V	17	MHz	
O_{ISO}	OFF isolation	$R_L = 50 \Omega$	$f = 100 \text{ kHz}$, see Figure 20	25°C	2.5 V	-66	dB	
X_{TALK}	Crosstalk	$R_L = 50 \Omega$	$f = 100 \text{ kHz}$, see Figure 21	25°C	2.5 V	-75	dB	
THD	Total harmonic distortion	$R_L = 600 \Omega$, $C_L = 35 \text{ pF}$,	$f = 20 \text{ Hz to } 20 \text{ kHz}$, see Figure 23	25°C	2.5 V	0.01%		
SUPPLY								
I_{CC}	Positive supply current	V_{COM} and $V_{IN} = V_{CC}$ or GND, V_{NC} and $V_{NO} = \text{Floating}$		25°C	2.7 V	0.2	1.1	μA
				Full			1.3	
		$V_{COM} = V_{CC} - 5.5$, $V_{IN} = V_{CC}$ or GND, V_{NC} and $V_{NO} = \text{Floating}$		Full	2.7 V		3.3	μA

6.6 Electrical Characteristics for 3.3-V Supply
 $V_{CC} = 3 \text{ V to } 3.6 \text{ V}$, $T_A = -40^\circ\text{C to } 85^\circ\text{C}$ (unless otherwise noted) ⁽¹⁾

PARAMETER	TEST CONDITIONS	T_A	V_{CC}	MIN	TYP	MAX	UNIT	
ANALOG SWITCH								
V_{COM} , V_{NO} , V_{NC}	Analog signal range			$V_{CC} - 5.5$		V_{CC}	V	
R_{on}	ON-state resistance	V_{NC} or $V_{NO} \leq V_{CC}$, 1.5 V, $V_{CC} = 5.5 \text{ V}$, $I_{COM} = -100 \text{ mA}$,	COM to NO or NC, see Figure 13	25°C	3 V	0.61	0.87	Ω
				Full			0.97	
ΔR_{on}	ON-state resistance match between channels	V_{NC} or $V_{NO} = 1.5 \text{ V}$, $I_{COM} = -100 \text{ mA}$,	COM to NO or NC, see Figure 13	25°C	3 V	0.024	0.13	Ω
				Full			0.13	
$R_{on(Flat)}$	ON-state resistance flatness	V_{NC} or $V_{NO} \leq V_{CC}$, 1.5 V, $V_{CC} = 5.5 \text{ V}$, $I_{COM} = -100 \text{ mA}$,	COM to NO or NC, see Figure 13	25°C	3 V	0.12	0.46	Ω
				Full			0.5	
R_{SH}	Shunt switch resistance	I_{NO} or $I_{NC} = 10 \text{ mA}$		Full	3 V	25	37	Ω
$I_{COM(ON)}$	COM ON leakage current	V_{NC} and $V_{NO} = \text{Open}$, $V_{COM} = V_{CC}$, $V_{CC} - 5.5 \text{ V}$,	COM to NO or NC, see Figure 15	25°C	3.6 V	-50	50	nA
				Full			-375	
DIGITAL CONTROL INPUTS (IN) ⁽²⁾								
V_{IH}	Input logic high			Full		1.4	5.5	V
V_{IL}	Input logic low						0.8	
I_{IH} , I_{IL}	Input leakage current	$V_{IN} = V_{CC}$ or 0		25°C	3.6 V	-250	250	nA
				Full			-250	

(1) The algebraic convention, whereby the most negative value is a minimum and the most positive value is a maximum

(2) All digital inputs of the device must be held at V_{CC} or GND to ensure proper device operation. Floating digital inputs will cause excessive current consumption. Refer to the TI application report, *Implications of Slow or Floating CMOS Inputs*, [SCBA004](#).

Electrical Characteristics for 3.3-V Supply (continued)
 $V_{CC} = 3\text{ V to }3.6\text{ V}$, $T_A = -40^\circ\text{C to }85^\circ\text{C}$ (unless otherwise noted) ⁽¹⁾

PARAMETER		TEST CONDITIONS		T_A	V_{CC}	MIN	TYP	MAX	UNIT
DYNAMIC									
t_{ON}	Turnon time	$V_{COM} = V_{CC}$, $R_L = 300\ \Omega$,	$C_L = 35\text{ pF}$, see Figure 17	25°C	3.3 V		34	80	ns
				Full	3 V to 3.6 V			120	
t_{OFF}	Turnoff time	$V_{COM} = V_{CC}$, $R_L = 300\ \Omega$,	$C_L = 35\text{ pF}$, see Figure 17	25°C	3.3 V		19	70	ns
				Full	3 V to 3.6 V			70	
t_{BBM}	Break-before-make time	See Figure 18		25°C	3.3 V	1	7		ns
Q_C	Charge injection	$V_{GEN} = 0$, $R_{GEN} = 0$,	$C_L = 1\text{ nF}$, see Figure 22	25°C	3.3 V		150		pC
$C_{COM(ON)}$	NC, NO, COM ON capacitance	$V_{COM} = V_{CC}$ or GND, $f = 10\text{ MHz}$	See Figure 16	25°C	3.3 V		370		pF
C_I	Digital input capacitance	$V_{IN} = V_{CC}$ or GND	See Figure 16	25°C	3.3 V		2.6		pF
BW	Bandwidth	$R_L = 50\ \Omega$, -3 dB	Switch ON,	25°C	3.3 V		17.5		MHz
O_{ISO}	OFF isolation	$R_L = 50\ \Omega$,	$f = 100\text{ kHz}$, see Figure 20	25°C	3.3 V		-68		dB
X_{TALK}	Crosstalk	$R_L = 50\ \Omega$,	$f = 100\text{ kHz}$, see Figure 21	25°C	3.3 V		-76		dB
THD	Total harmonic distortion	$R_L = 600\ \Omega$, $C_L = 35\text{ pF}$,	$f = 20\text{ Hz to }20\text{ kHz}$, see Figure 23	25°C	3.3 V		0.008%		
SUPPLY									
I_{CC}	Positive supply current	V_{COM} and $V_{IN} = V_{CC}$ or GND, V_{NC} and $V_{NO} = \text{Floating}$		25°C	3.6 V		0.1	1.2	μA
				Full				1.3	
				Full	3.6 V				3.4

6.7 Electrical Characteristics for 5-V Supply

 $V_{CC} = 4.5\text{ V to }5.5\text{ V}$, $T_A = -40^\circ\text{C to }85^\circ\text{C}$ (unless otherwise noted) ⁽¹⁾

PARAMETER		TEST CONDITIONS		T_A	V_{CC}	MIN	TYP	MAX	UNIT
ANALOG SWITCH									
V_{COM}, V_{NO}, V_{NC}	Analog signal range					$V_{CC} - 5.5$		V_{CC}	V
R_{on}	ON-state resistance	V_{NC} or $V_{NO} = V_{CC}, 1.6\text{ V}$, $V_{CC} = -5.5\text{ V}$, $I_{COM} = -100\text{ mA}$,	COM to NO or NC, see Figure 13	25°C	4.5 V	0.52	0.74		Ω
				Full			0.83		
ΔR_{on}	ON-state resistance match between channels	V_{NC} or $V_{NO} = 1.6\text{ V}$, $I_{COM} = -100\text{ mA}$,	COM to NO or NC, see Figure 13	25°C	4.5 V	0.04	0.23		Ω
				Full			0.30		
$R_{on(flat)}$	ON-state resistance flatness	V_{NC} or $V_{NO} = V_{CC}, 1.6\text{ V}$, $V_{CC} = -5.5\text{ V}$, $I_{COM} = -100\text{ mA}$,	COM to NO or NC, see Figure 13	25°C	4.5 V	0.076	0.46		Ω
				Full			0.5		
R_{SH}	Shunt switch resistance	I_{NO} or $I_{NC} = 10\text{ mA}$		Full	4.5 V		16	36	Ω
$I_{COM(ON)}$	COM ON leakage current	V_{NC} and $V_{NO} = \text{Open}$, $V_{COM} = V_{CC}, V_{CC} - 5.5\text{ V}$,	See Figure 15	25°C	5.5 V	-50		50	nA
				Full			-375		
DIGITAL CONTROL INPUTS (IN) ⁽²⁾									
V_{IH}	Input logic high			Full		2.4		5.5	V
V_{IL}	Input logic low							0.8	
I_{IH}, I_{IL}	Input leakage current	$V_{IN} = V_{CC}$ or 0		25°C	5.5 V	-250		250	nA
				Full			-250		
DYNAMIC									
t_{ON}	Turnon time	$V_{COM} = V_{CC}$, $R_L = 300\ \Omega$,	$C_L = 35\text{ pF}$, see Figure 17	25°C	5 V		27	80	ns
				Full	4.5 V to 5.5 V			80	
t_{OFF}	Turnoff time	$V_{COM} = V_{CC}$, $R_L = 300\ \Omega$,	$C_L = 35\text{ pF}$, see Figure 17	25°C	5 V		13	70	ns
				Full	4.5 V to 5.5 V			70	
t_{BBM}	Break-before-make time	$V_{NC} = V_{NO} = V_{CC}/2$ $R_L = 300\ \Omega$,	$C_L = 35\text{ pF}$,	25°C	5 V	1	3.5		ns
Q_C	Charge injection	$V_{GEN} = 0$, $R_{GEN} = 0$,	$C_L = 1\text{ nF}$, see Figure 22	25°C	5 V		10		pC
$C_{COM(ON)}$	NC, NO, COM ON capacitance	$V_{COM} = V_{CC}$ or GND,	See Figure 16	25°C	5 V		370		pF
C_I	Digital input capacitance	$V_{IN} = V_{CC}$ or GND	See Figure 16	25°C	5 V		2.6		pF
BW	Bandwidth	$R_L = 50\ \Omega$,		25°C	5 V		18.3		MHz
O_{ISO}	OFF isolation	$R_L = 50\ \Omega$,	$f = 100\text{ kHz}$, see Figure 20	25°C	5 V		-70		dB
X_{TALK}	Crosstalk	$R_L = 50\ \Omega$,	$f = 100\text{ kHz}$, see Figure 21	25°C	5 V		-78		dB
THD	Total harmonic distortion	$R_L = 600\ \Omega$, $C_L = 35\text{ pF}$,	$f = 20\text{ Hz to }20\text{ kHz}$, see Figure 23	25°C	5 V		0.009%		
SUPPLY									
I_{CC}	Positive supply current	V_{COM} and $V_{IN} = V_{CC}$ or GND, V_{NC} and $V_{NO} = \text{Floating}$		25°C	5.5 V		0.2	1.3	μA
				Full				3.5	
		$V_{COM} = V_{CC} - 5.5$, $V_{IN} = V_{CC}$ or GND, V_{NC} and $V_{NO} = \text{Floating}$	Full				5		

(1) The algebraic convention, whereby the most negative value is a minimum and the most positive value is a maximum

(2) All unused digital inputs of the device must be held at V_{CC} or GND to ensure proper device operation. Floating digital inputs will cause excessive current consumption. Refer to the TI application report, *Implications of Slow or Floating CMOS Inputs*, [SCBA004](#).

6.8 Typical Characteristics

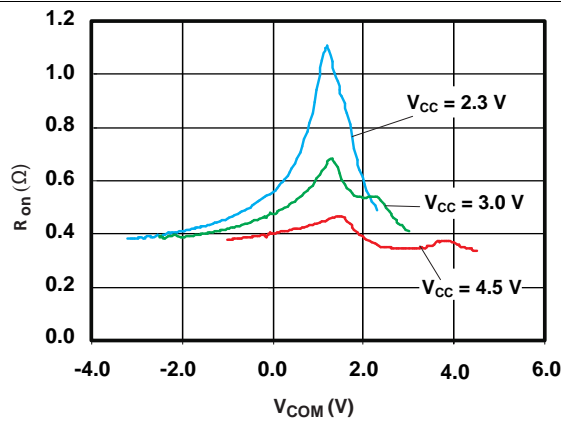

Figure 1. R_{on} vs V_{COM}

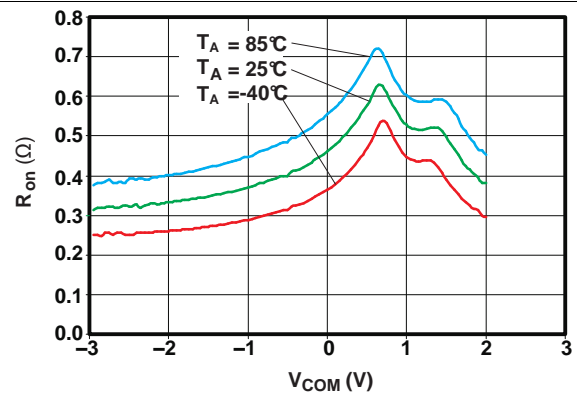

Figure 2. R_{on} vs V_{COM} ($V_{CC} = 2.7\text{ V}$)

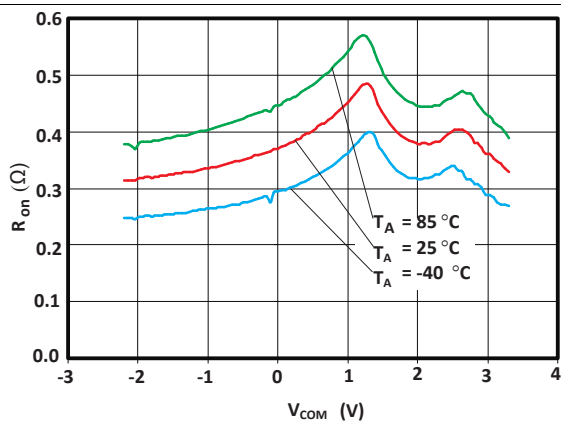

Figure 3. R_{on} vs V_{COM} ($V_{CC} = 3.3\text{ V}$)

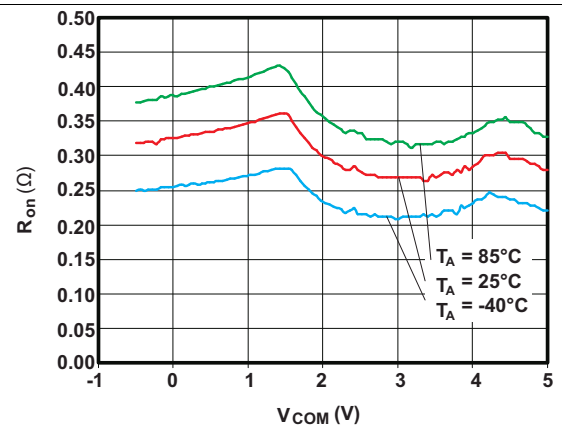

Figure 4. R_{on} vs V_{COM} ($V_{CC} = 5\text{ V}$)

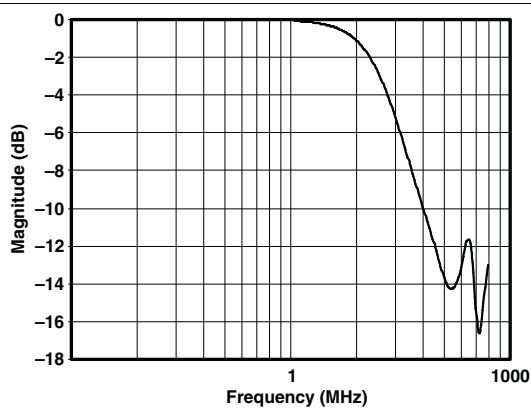

Figure 5. Insertion Loss

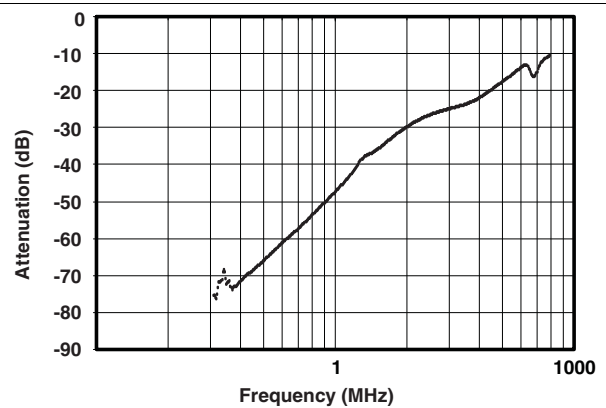
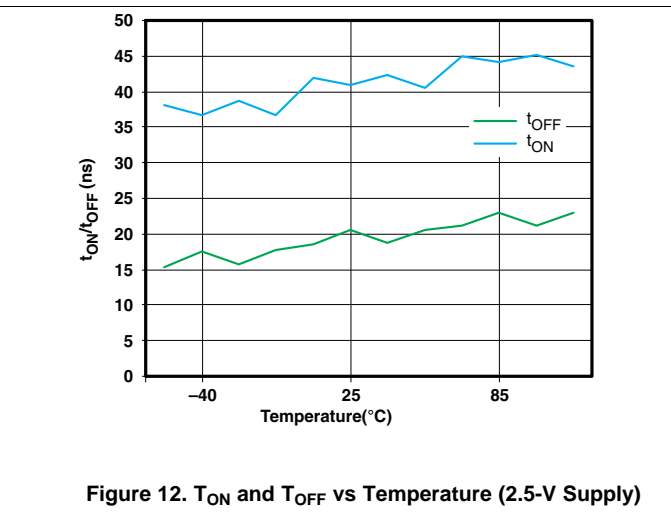
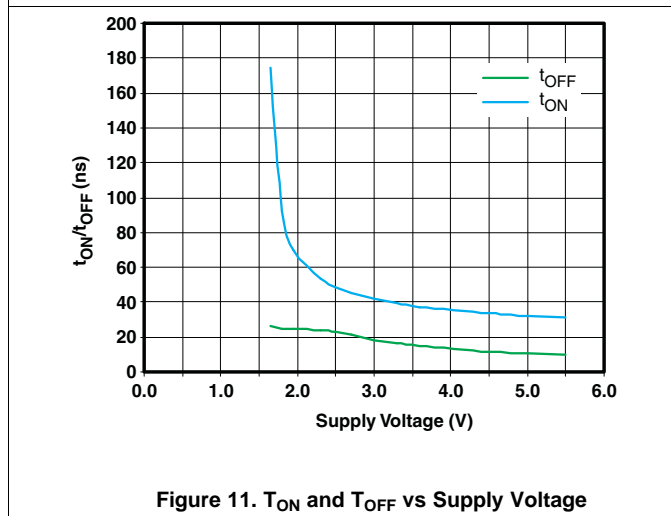
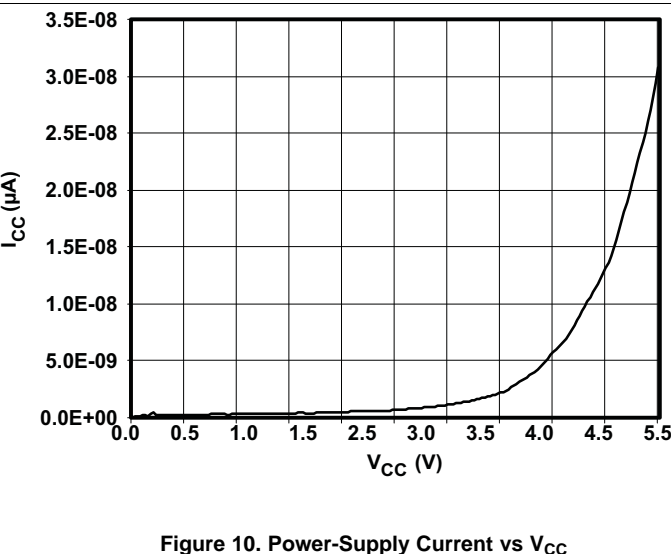
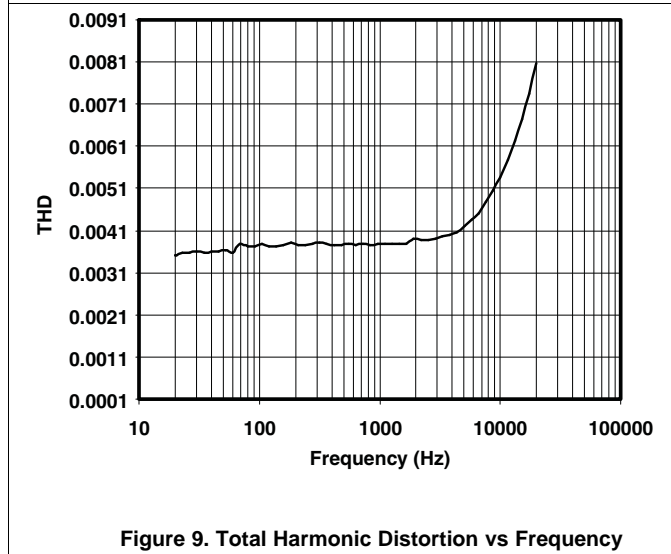
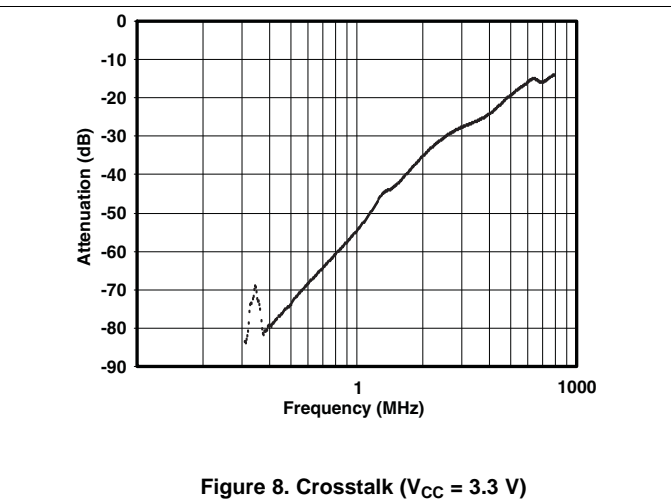
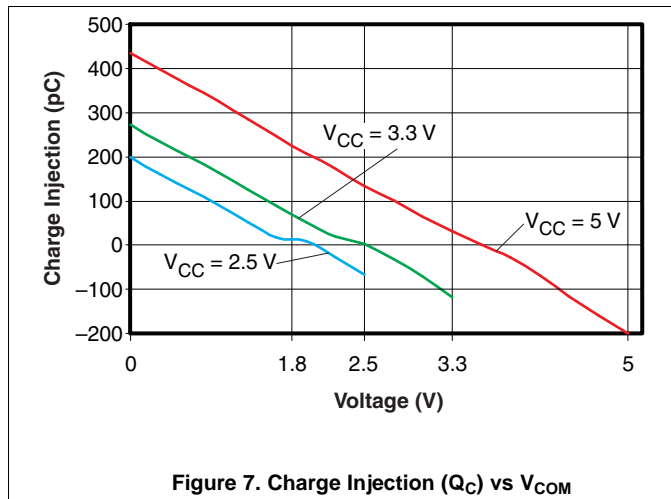

Figure 6. Off Isolation vs Frequency

Typical Characteristics (continued)



7 Parameter Measurement Information

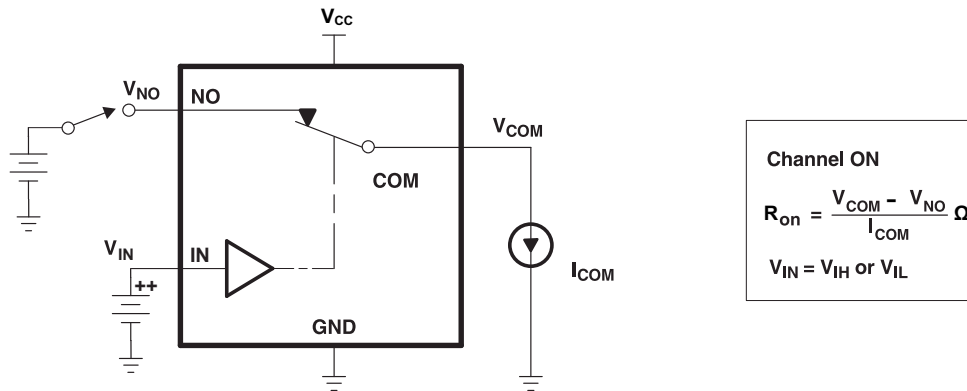

Figure 13. ON-State Resistance (R_{on})

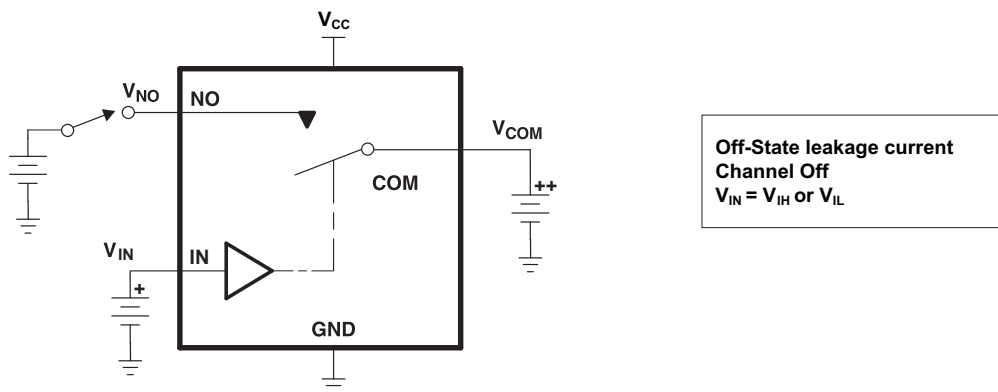

Figure 14. OFF-State Leakage Current ($I_{COM(OFF)}$, $I_{NO(OFF)}$)

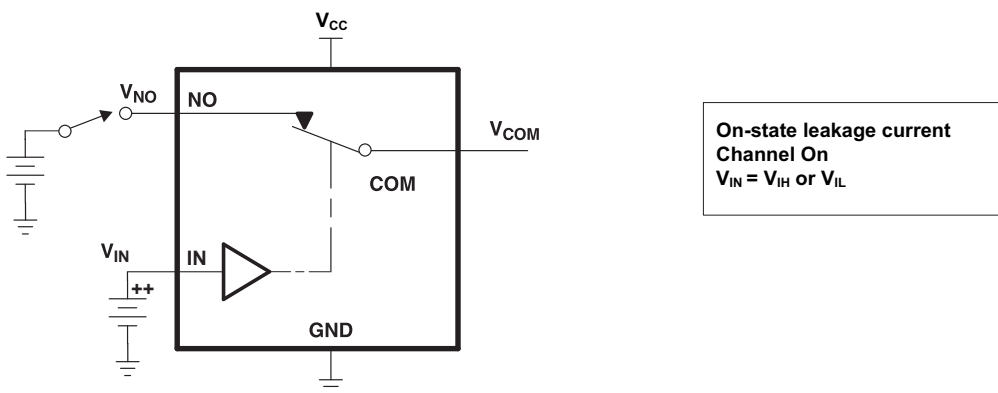

Figure 15. ON-State Leakage Current ($I_{COM(ON)}$, $I_{NO(ON)}$)

Parameter Measurement Information (continued)

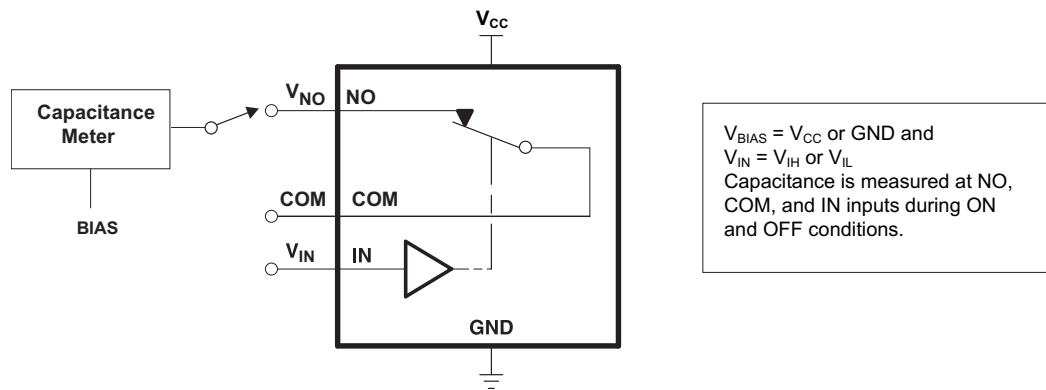
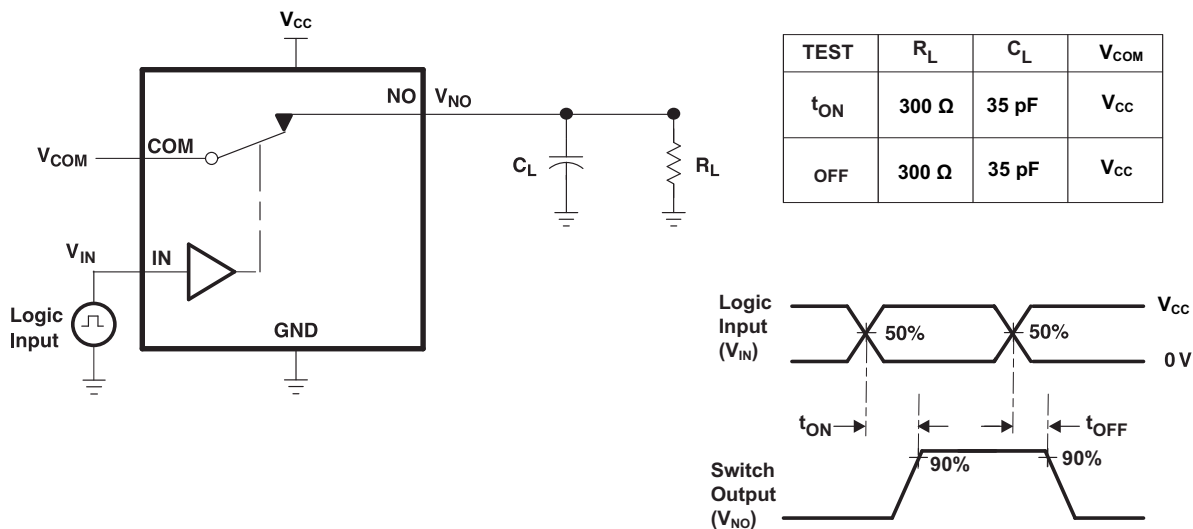

Figure 16. Capacitance (C_I , $C_{COM(OFF)}$, $C_{COM(ON)}$, $C_{NO(OFF)}$, $C_{NO(ON)}$)



- A. All input pulses are supplied by generators having the following characteristics:
 $PRR \leq 10 \text{ MHz}$, $Z_O = 50 \Omega$, $t_r < 5 \text{ ns}$, $t_f < 5 \text{ ns}$.
- B. C_L includes probe and jig capacitance.

Figure 17. Turnon (t_{ON}) and Turnoff Time (t_{OFF})

Parameter Measurement Information (continued)

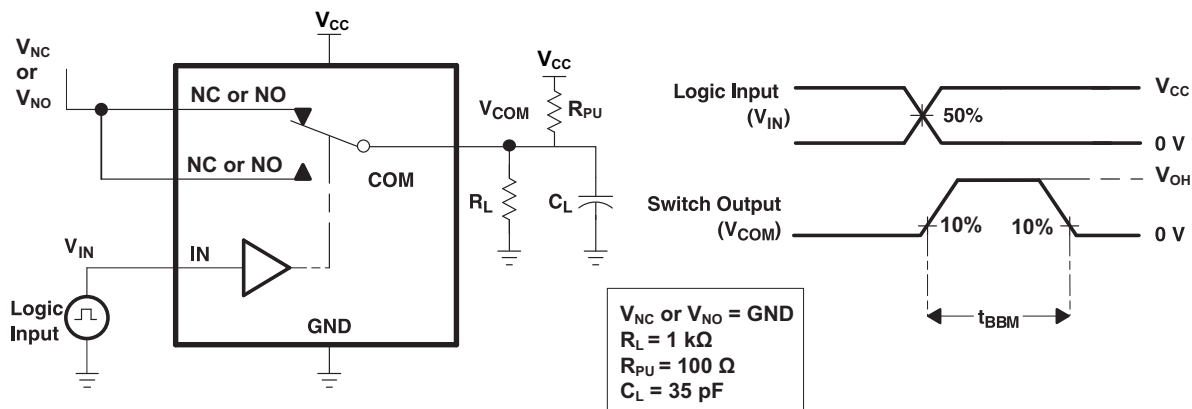

- A. C_L includes probe and jig capacitance.
- B. All input pulses are supplied by generators having the following characteristics:
 $PRR \leq 10 \text{ MHz}$, $Z_O = 50 \Omega$, $t_r < 5 \text{ ns}$, $t_f < 5 \text{ ns}$.

Figure 18. Break-Before-Make Time (t_{BBM})

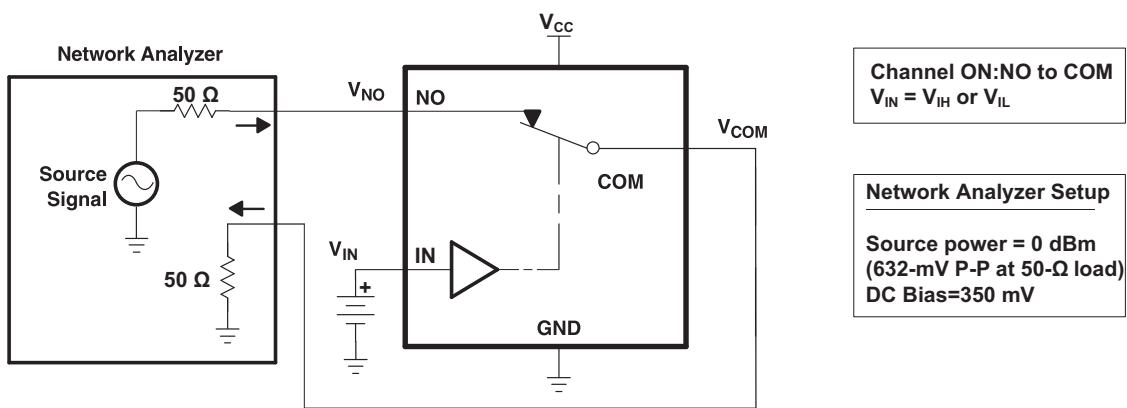

Figure 19. Bandwidth (BW)

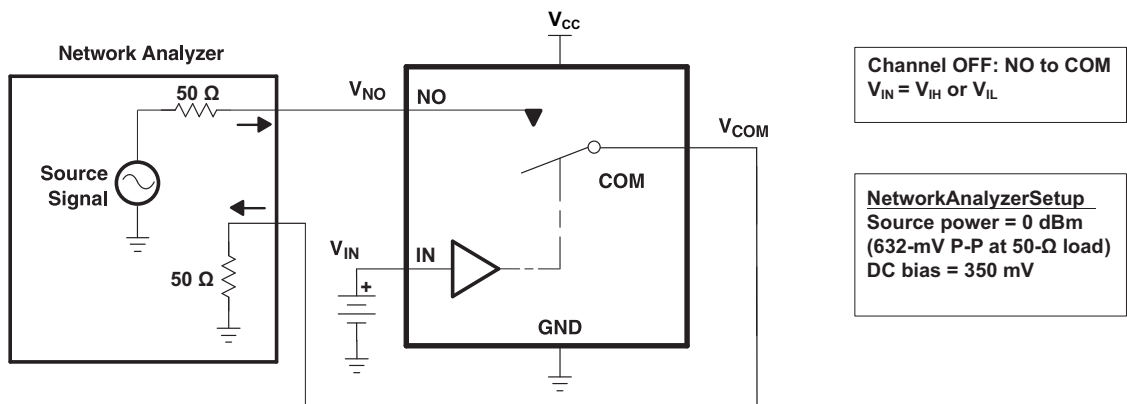

Figure 20. OFF Isolation (O_{ISO})

Parameter Measurement Information (continued)

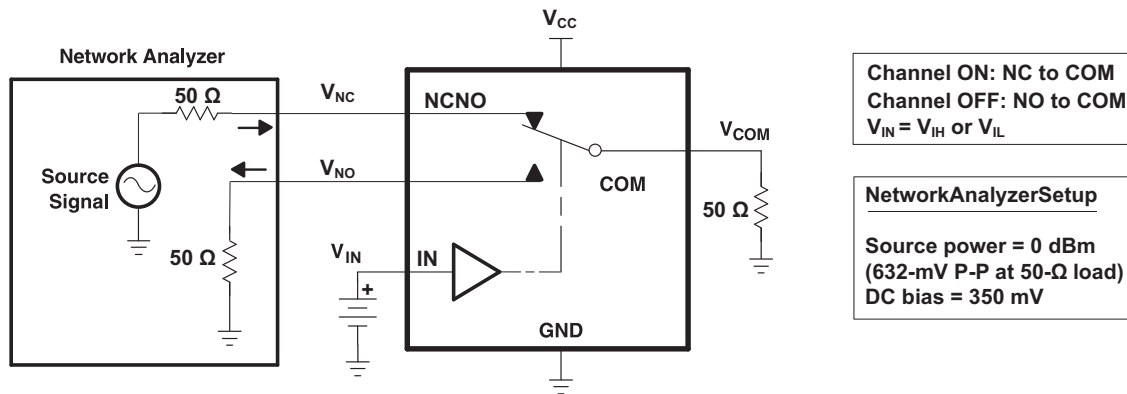
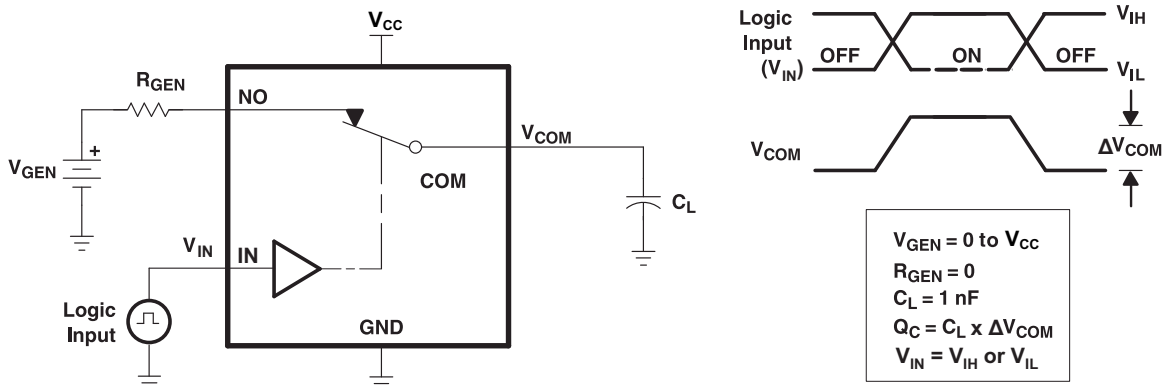
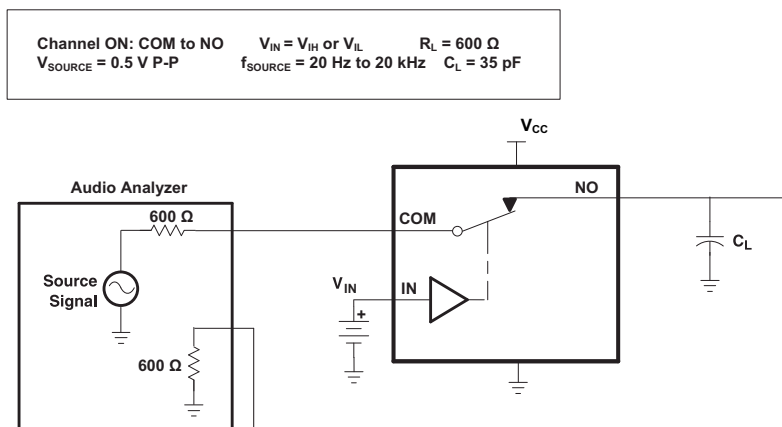

Figure 21. Crosstalk (X_{TALK})



- A. All input pulses are supplied by generators having the following characteristics: PRR ≤ 10 MHz, $Z_O = 50 \Omega$, $t_r < 5$ ns, $t_f < 5$ ns.
- B. C_L includes probe and jig capacitance.

Figure 22. Charge Injection (Q_C)



C_L includes probe and jig capacitance.

Figure 23. Total Harmonic Distortion (THD)

8 Detailed Description

8.1 Overview

The TS5A22364 is a bidirectional 2-channel, single-pole, double-throw (SPDT) analog switch designed to operate from 2.3-V to 5.5-V power supply. The device features negative signal swing capability that allows signals below ground to pass through the switch without distortion. Additionally, the TS5A22364 includes an internal shunt switch, which automatically discharges any capacitance at the NC or NO terminals when they are not connected to COM. Discharging the capacitance reduces the audible click and pop noise when switching between two sources. The break-before-make feature prevents signal distortion during the transferring of a signal from one path to another. Low ON-state resistance, excellent channel-to-channel ON-state resistance matching, and minimal total harmonic distortion (THD) performance are ideal for audio applications.

8.2 Functional Block Diagram

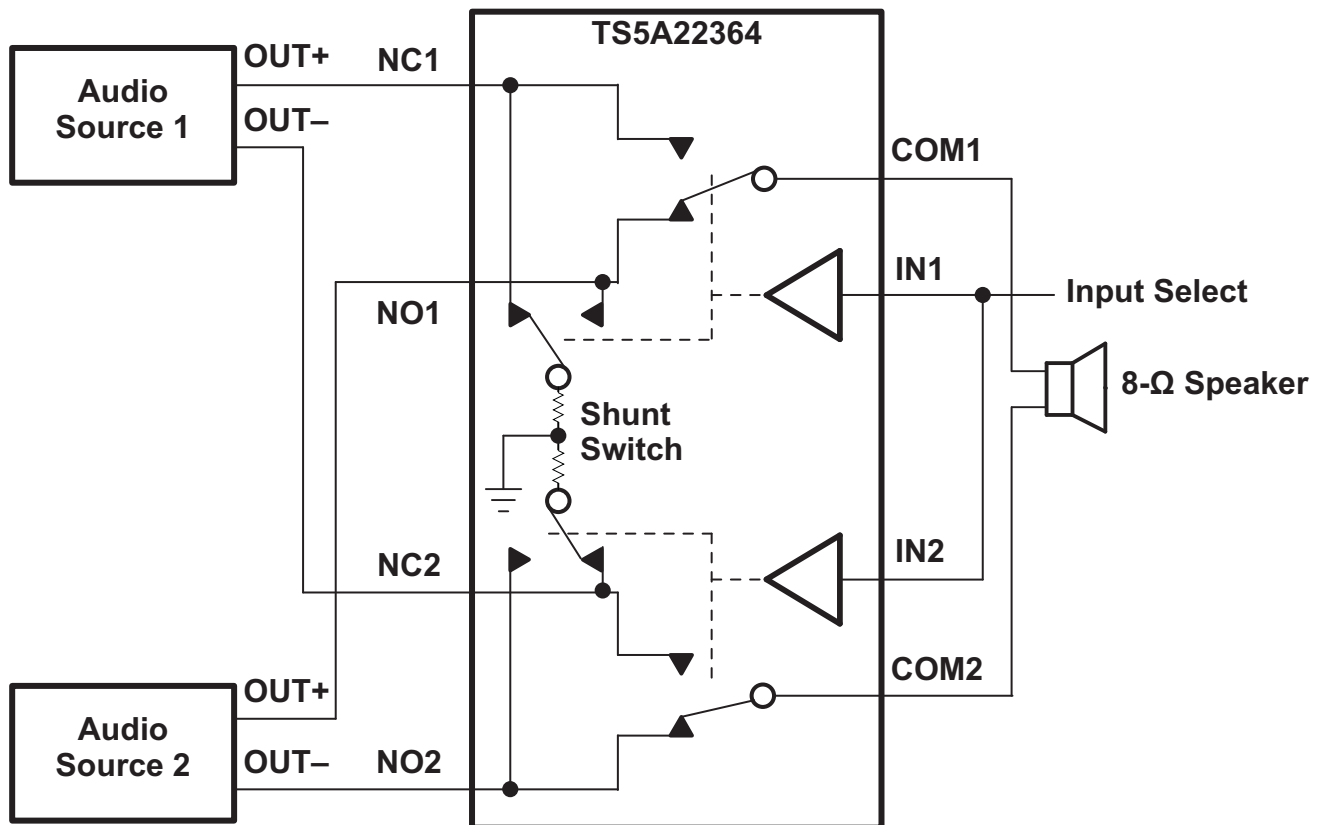

8.3 Feature Description

8.3.1 Click and Pop Reduction

The shunt resistors in the TS5A22364 automatically discharge any capacitance at the NC or NO terminals when they are not connected to COM. This reduces the audible click-and-pop sounds that occur when switching between audio sources. Audible clicks and pops are caused when a step DC voltage is switched into the speaker. By automatically discharging the side that is not connected, any residual DC voltage is removed, thereby reducing the clicks and pops.

8.3.2 Negative Signal Swing Capability

The TS5A22364 2-channel SPDT switch features negative signal capability that allows signals below ground to pass through without distortion. These analog switches operate from a single 2.3-V to 5.5-V supply. The input and output signal swing of the device is dependant of the supply voltage V_{CC} . The device passes signals as high as V_{CC} and as low as $V_{CC} - 5.5$ V, including signals below ground with minimal distortion. The OFF state signal path (either NC or NO) during the operation of TS5A22364 cannot handle negative DC voltage

Table 1 shows the input/output signal swing the user can get with different supply voltages.

Table 1. Input/Output Signal Swing

SUPPLY VOLTAGE, V_{CC}	MINIMUM $V_{NC}, V_{NO}, V_{COM} = V_{CC} - 5.5$ V	MAXIMUM $V_{NC}, V_{NO}, V_{COM} = V_{CC}$
	ON-STATE SIGNAL PATH	
5.5 V	0 V	5.5 V
4.5 V	-1.0 V	4.5 V
3.6 V	-1.9 V	3.6 V
3.0 V	-2.5 V	3.0 V
2.7 V	-2.8 V	2.7 V
2.3 V	-3.2 V	2.3 V

8.4 Device Functional Modes

The function table for TS5A22364 is shown in Table 2.

Table 2. Function Table

IN	NC TO COM, COM TO NC	NO TO COM, COM TO NO
L	ON	OFF
H	OFF	ON

9 Application and Implementation

NOTE

Information in the following applications sections is not part of the TI component specification, and TI does not warrant its accuracy or completeness. TI's customers are responsible for determining suitability of components for their purposes. Customers should validate and test their design implementation to confirm system functionality.

9.1 Application Information

The shunt resistors on the TS5A22364 automatically discharge any capacitance at the NC or NO terminals when they are not connected to COM. This reduces audible click-and-pop sounds that occur when switching between audio sources. Audible clicks and pops are caused when a step DC voltage is switched into the speaker. By automatically discharging the side that is not connected, any residual DC voltage is removed, thereby reducing the clicks and pops.

9.2 Typical Application

The shunt resistors on the TS5A22364 are designed to automatically discharge any residual charge at the NC or NO terminals when they are not connected to COM. This reduces audible click-and-pop sounds that occur when switching between audio sources. Audible clicks and pops are caused when a step DC voltage is switched into the speaker. By automatically discharging the side that is not used for the signal path, any residual charge voltage is discharged to ground, thereby reducing the clicks and pops. The amount of power that the shunt switch can discharge from the inactive signal path is limited by the shunt resistors (R_{sh}) power dissipation. TI recommends that during operation, the current through the shunt path should be limited to ± 10 mA.

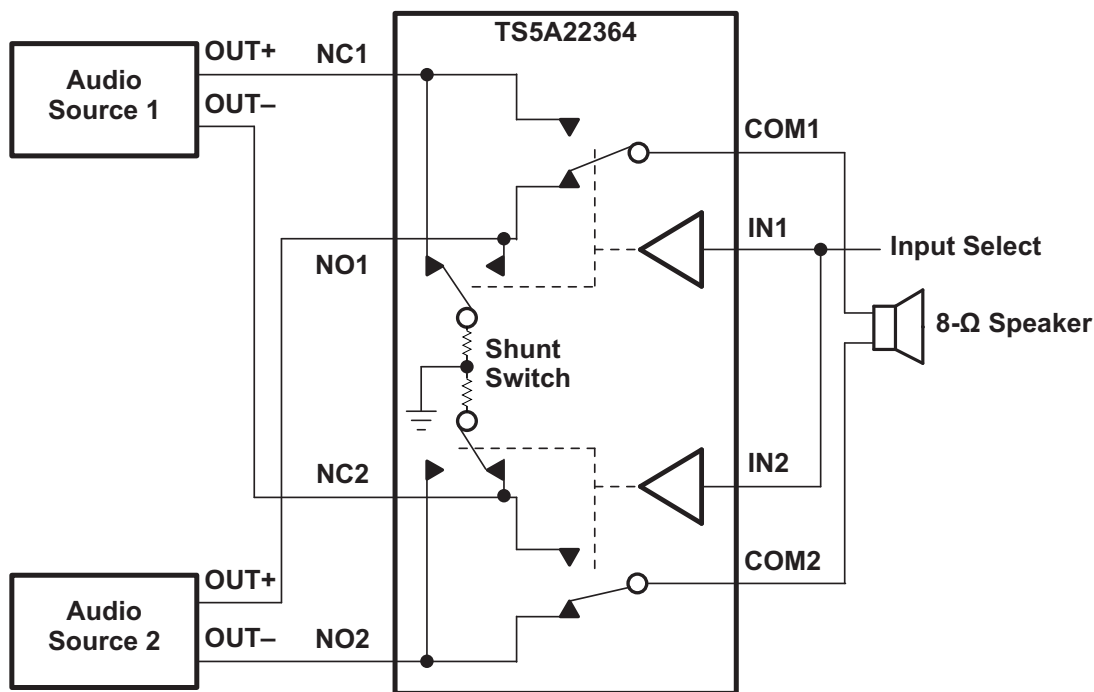

Figure 24. Shunt Switch (TS5A22364)

Typical Application (continued)

9.2.1 Design Requirements

Tie the digitally controlled inputs select pins IN1 and IN2 to V_{CC} or GND to avoid unwanted switch states and high current consumption that could result if the logic control pins are left floating.

9.2.2 Detailed Design Procedure

Select the appropriate supply voltage to cover the entire voltage swing of the signal passing through the switch because the TS5A22364 operates from a single 2.3-V to 5.5-V supply and the input and output signal swing of the device is dependant of the supply voltage, V_{CC} . The device will pass signals as high as V_{CC} and as low as $V_{CC} - 5.5$ V. Use [Table 1](#) as a guide for selecting supply voltage based on the signal passing through the ON-state switch path.

Ensure that the device is powered up with a valid supply voltage on VCC before a voltage can be applied to the signal paths NC and NO.

9.2.3 Application Curve

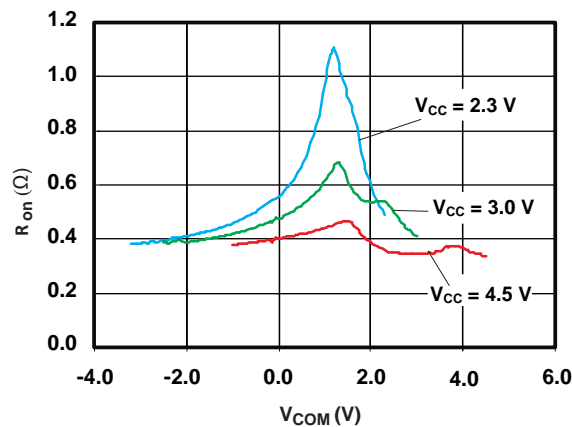

Figure 25. R_{on} vs V_{COM}

10 Power Supply Recommendations

The TS5A22364 operates from a single 2.3-V to 5.5-V supply. The device must be powered up with a supply voltage on VCC before a voltage can be applied to the signal paths NC and NO. TI recommends to include a 100- μ s delay after VCC is at voltage before applying a signal on NC and NO paths

It is also good practice to place a 0.1- μ F bypass capacitor on the supply pin VCC to GND to smooth out lower frequency noise to provide better load regulation across the frequency spectrum.

11 Layout

11.1 Layout Guidelines

TI recommends placing a bypass capacitor as close to the supply pin VCC as possible to help smooth out lower frequency noise to provide better load regulation across the frequency spectrum.

Minimize trace lengths and vias on the signal paths in order to preserve signal integrity.

11.2 Layout Example

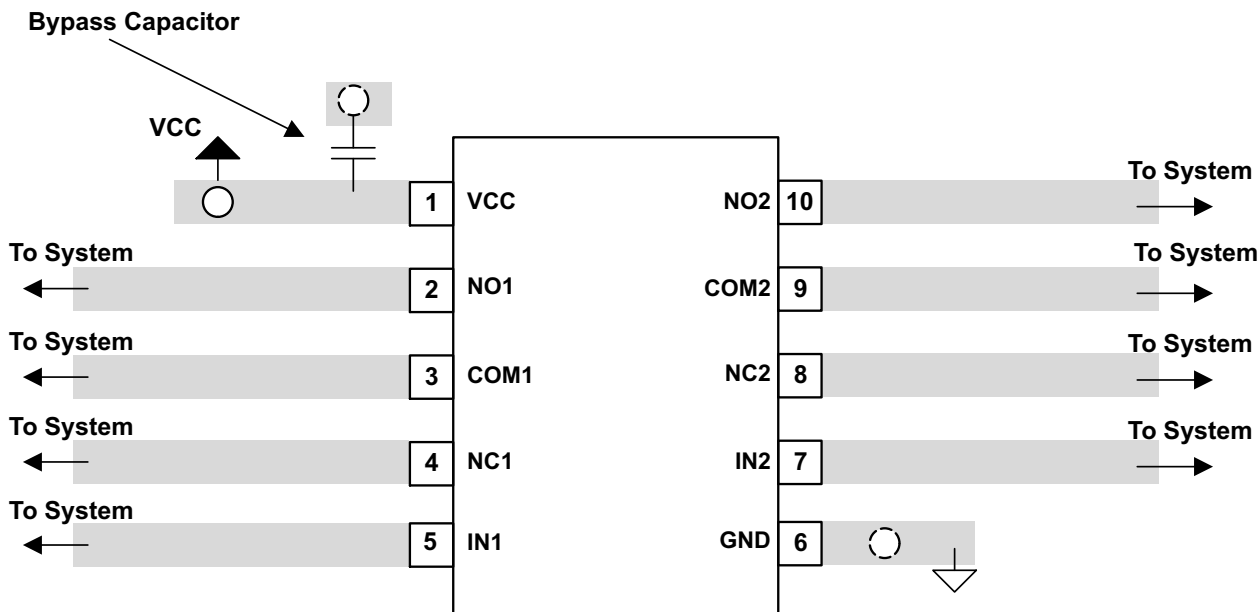
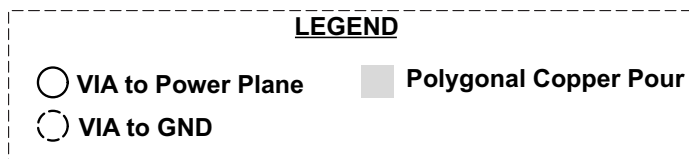

Figure 26. Layout Example of TS5A22364

12 Device and Documentation Support

12.1 Community Resources

The following links connect to TI community resources. Linked contents are provided "AS IS" by the respective contributors. They do not constitute TI specifications and do not necessarily reflect TI's views; see TI's [Terms of Use](#).

TI E2E™ Online Community *TI's Engineer-to-Engineer (E2E) Community*. Created to foster collaboration among engineers. At e2e.ti.com, you can ask questions, share knowledge, explore ideas and help solve problems with fellow engineers.

Design Support *TI's Design Support* Quickly find helpful E2E forums along with design support tools and contact information for technical support.

12.2 Trademarks

E2E is a trademark of Texas Instruments.
All other trademarks are the property of their respective owners.

12.3 Electrostatic Discharge Caution



These devices have limited built-in ESD protection. The leads should be shorted together or the device placed in conductive foam during storage or handling to prevent electrostatic damage to the MOS gates.

12.4 Glossary

[SLYZ022](#) — *TI Glossary*.

This glossary lists and explains terms, acronyms, and definitions.

13 Mechanical, Packaging, and Orderable Information

The following pages include mechanical, packaging, and orderable information. This information is the most current data available for the designated devices. This data is subject to change without notice and revision of this document. For browser-based versions of this data sheet, refer to the left-hand navigation.

PACKAGING INFORMATION

Orderable Device	Status (1)	Package Type	Package Drawing	Pins	Package Qty	Eco Plan (2)	Lead/Ball Finish (6)	MSL Peak Temp (3)	Op Temp (°C)	Device Marking (4/5)	Samples
TS5A22364DGSR	ACTIVE	VSSOP	DGS	10	2500	Green (RoHS & no Sb/Br)	CU NIPDAU	Level-1-260C-UNLIM	-40 to 85	(38Q ~ 38R)	Samples
TS5A22364DGSRG4	ACTIVE	VSSOP	DGS	10	2500	Green (RoHS & no Sb/Br)	CU NIPDAU	Level-1-260C-UNLIM	-40 to 85	(38Q ~ 38R)	Samples
TS5A22364DRCR	ACTIVE	VSON	DRC	10	3000	Green (RoHS & no Sb/Br)	CU NIPDAU	Level-2-260C-1 YEAR	-40 to 85	ZVF	Samples
TS5A22364YZPR	ACTIVE	DSBGA	YZP	10	3000	Green (RoHS & no Sb/Br)	Call TI SNAGCU	Level-1-260C-UNLIM	-40 to 85	(38 ~ 382)	Samples

(1) The marketing status values are defined as follows:

ACTIVE: Product device recommended for new designs.

LIFEBUY: TI has announced that the device will be discontinued, and a lifetime-buy period is in effect.

NRND: Not recommended for new designs. Device is in production to support existing customers, but TI does not recommend using this part in a new design.

PREVIEW: Device has been announced but is not in production. Samples may or may not be available.

OBSOLETE: TI has discontinued the production of the device.

(2) Eco Plan - The planned eco-friendly classification: Pb-Free (RoHS), Pb-Free (RoHS Exempt), or Green (RoHS & no Sb/Br) - please check <http://www.ti.com/productcontent> for the latest availability information and additional product content details.

TBD: The Pb-Free/Green conversion plan has not been defined.

Pb-Free (RoHS): TI's terms "Lead-Free" or "Pb-Free" mean semiconductor products that are compatible with the current RoHS requirements for all 6 substances, including the requirement that lead not exceed 0.1% by weight in homogeneous materials. Where designed to be soldered at high temperatures, TI Pb-Free products are suitable for use in specified lead-free processes.

Pb-Free (RoHS Exempt): This component has a RoHS exemption for either 1) lead-based flip-chip solder bumps used between the die and package, or 2) lead-based die adhesive used between the die and leadframe. The component is otherwise considered Pb-Free (RoHS compatible) as defined above.

Green (RoHS & no Sb/Br): TI defines "Green" to mean Pb-Free (RoHS compatible), and free of Bromine (Br) and Antimony (Sb) based flame retardants (Br or Sb do not exceed 0.1% by weight in homogeneous material)

(3) MSL, Peak Temp. - The Moisture Sensitivity Level rating according to the JEDEC industry standard classifications, and peak solder temperature.

(4) There may be additional marking, which relates to the logo, the lot trace code information, or the environmental category on the device.

(5) Multiple Device Markings will be inside parentheses. Only one Device Marking contained in parentheses and separated by a "~" will appear on a device. If a line is indented then it is a continuation of the previous line and the two combined represent the entire Device Marking for that device.

(6) Lead/Ball Finish - Orderable Devices may have multiple material finish options. Finish options are separated by a vertical ruled line. Lead/Ball Finish values may wrap to two lines if the finish value exceeds the maximum column width.

Important Information and Disclaimer: The information provided on this page represents TI's knowledge and belief as of the date that it is provided. TI bases its knowledge and belief on information provided by third parties, and makes no representation or warranty as to the accuracy of such information. Efforts are underway to better integrate information from third parties. TI has taken and continues to take reasonable steps to provide representative and accurate information but may not have conducted destructive testing or chemical analysis on incoming materials and chemicals. TI and TI suppliers consider certain information to be proprietary, and thus CAS numbers and other limited information may not be available for release.

In no event shall TI's liability arising out of such information exceed the total purchase price of the TI part(s) at issue in this document sold by TI to Customer on an annual basis.

OTHER QUALIFIED VERSIONS OF TS5A22364 :

- Automotive: [TS5A22364-Q1](#)

NOTE: Qualified Version Definitions:

- Automotive - Q100 devices qualified for high-reliability automotive applications targeting zero defects

TAPE AND REEL INFORMATION



QUADRANT ASSIGNMENTS FOR PIN 1 ORIENTATION IN TAPE



*All dimensions are nominal

Device	Package Type	Package Drawing	Pins	SPQ	Reel Diameter (mm)	Reel Width W1 (mm)	A0 (mm)	B0 (mm)	K0 (mm)	P1 (mm)	W (mm)	Pin1 Quadrant
TS5A22364DGSR	VSSOP	DGS	10	2500	330.0	12.4	5.3	3.4	1.4	8.0	12.0	Q1
TS5A22364DRCR	VSON	DRC	10	3000	330.0	12.4	3.3	3.3	1.1	8.0	12.0	Q2
TS5A22364YZPR	DSBGA	YZP	10	3000	178.0	9.2	1.49	1.99	0.63	4.0	8.0	Q2

TAPE AND REEL BOX DIMENSIONS

*All dimensions are nominal

Device	Package Type	Package Drawing	Pins	SPQ	Length (mm)	Width (mm)	Height (mm)
TS5A22364DGSR	VSSOP	DGS	10	2500	358.0	335.0	35.0
TS5A22364DRCR	VSON	DRC	10	3000	367.0	367.0	35.0
TS5A22364YZPR	DSBGA	YZP	10	3000	220.0	220.0	35.0

DGS (S-PDSO-G10)

PLASTIC SMALL-OUTLINE PACKAGE



- NOTES:
- A. All linear dimensions are in millimeters.
 - B. This drawing is subject to change without notice.
 - C. Body dimensions do not include mold flash or protrusion.
 - D. Falls within JEDEC MO-187 variation BA.

DGS (S-PDSO-G10)

PLASTIC SMALL OUTLINE PACKAGE

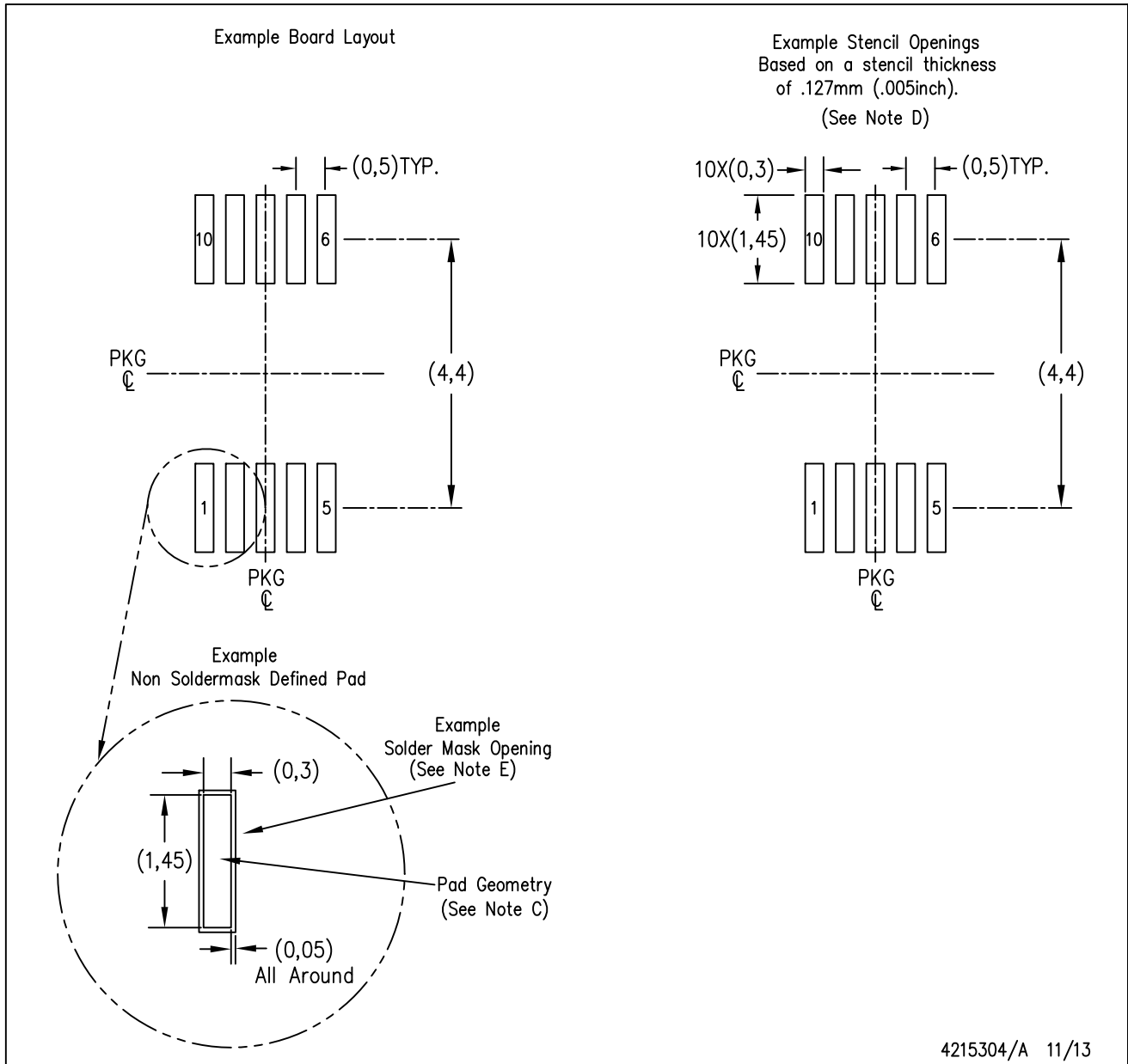

- NOTES:
- All linear dimensions are in millimeters.
 - This drawing is subject to change without notice.
 - Publication IPC-7351 is recommended for alternate designs.
 - Laser cutting apertures with trapezoidal walls and also rounding corners will offer better paste release. Customers should contact their board assembly site for stencil design recommendations. Refer to IPC-7525 for other stencil recommendations.
 - Customers should contact their board fabrication site for solder mask tolerances between and around signal pads.

DRC (S-PVSON-N10)

PLASTIC SMALL OUTLINE NO-LEAD

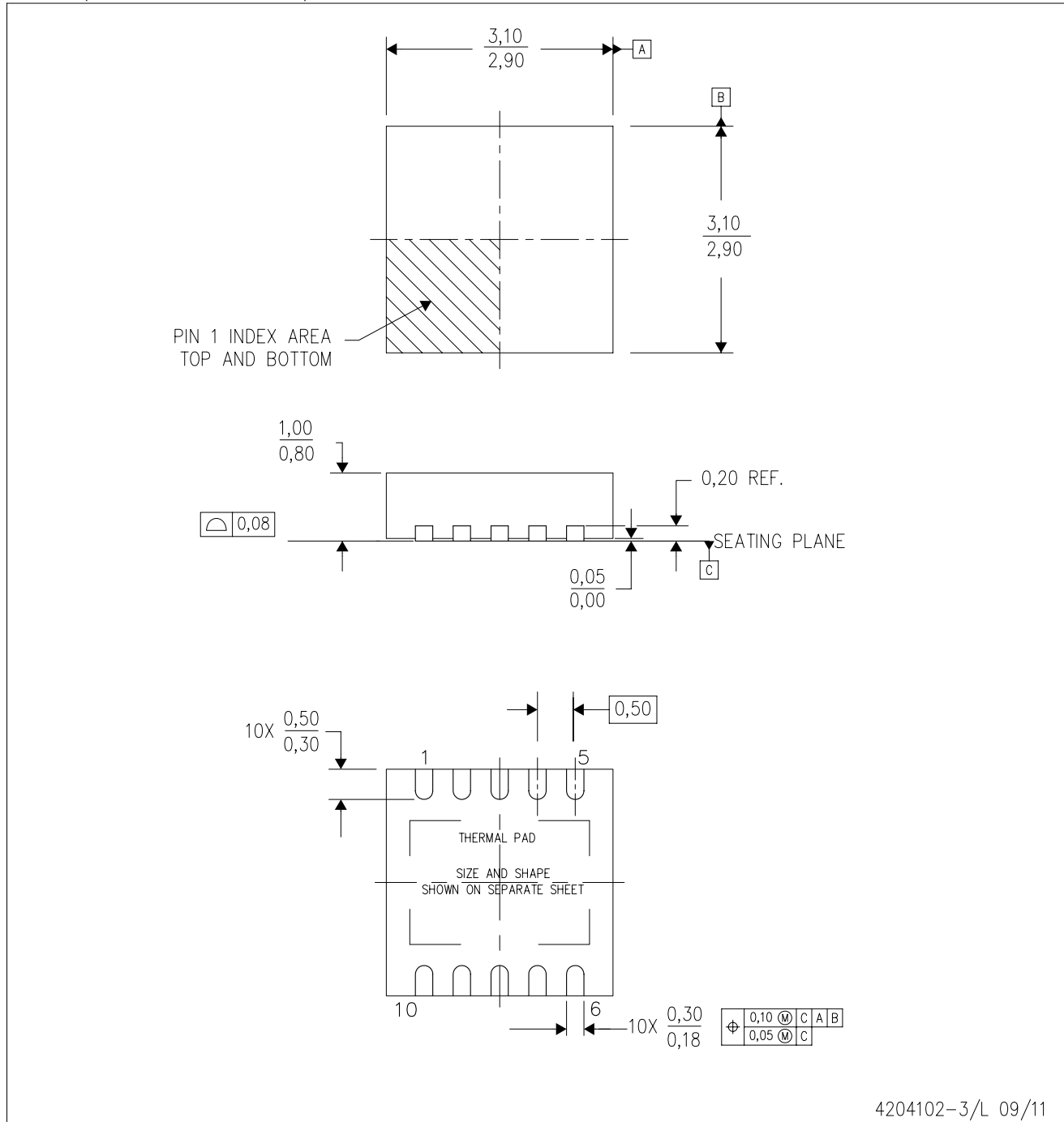

4204102-3/L 09/11

- NOTES:
- All linear dimensions are in millimeters. Dimensioning and tolerancing per ASME Y14.5M-1994.
 - This drawing is subject to change without notice.
 - Small Outline No-Lead (SON) package configuration.
 - The package thermal pad must be soldered to the board for thermal and mechanical performance, if present.
 - See the additional figure in the Product Data Sheet for details regarding the exposed thermal pad features and dimensions, if present

THERMAL PAD MECHANICAL DATA

DRC (S-PVSON-N10)

PLASTIC SMALL OUTLINE NO-LEAD

THERMAL INFORMATION

This package incorporates an exposed thermal pad that is designed to be attached directly to an external heatsink. The thermal pad must be soldered directly to the printed circuit board (PCB). After soldering, the PCB can be used as a heatsink. In addition, through the use of thermal vias, the thermal pad can be attached directly to the appropriate copper plane shown in the electrical schematic for the device, or alternatively, can be attached to a special heatsink structure designed into the PCB. This design optimizes the heat transfer from the integrated circuit (IC).

For information on the Quad Flatpack No-Lead (QFN) package and its advantages, refer to Application Report, QFN/SON PCB Attachment, Texas Instruments Literature No. SLUA271. This document is available at www.ti.com.

The exposed thermal pad dimensions for this package are shown in the following illustration.

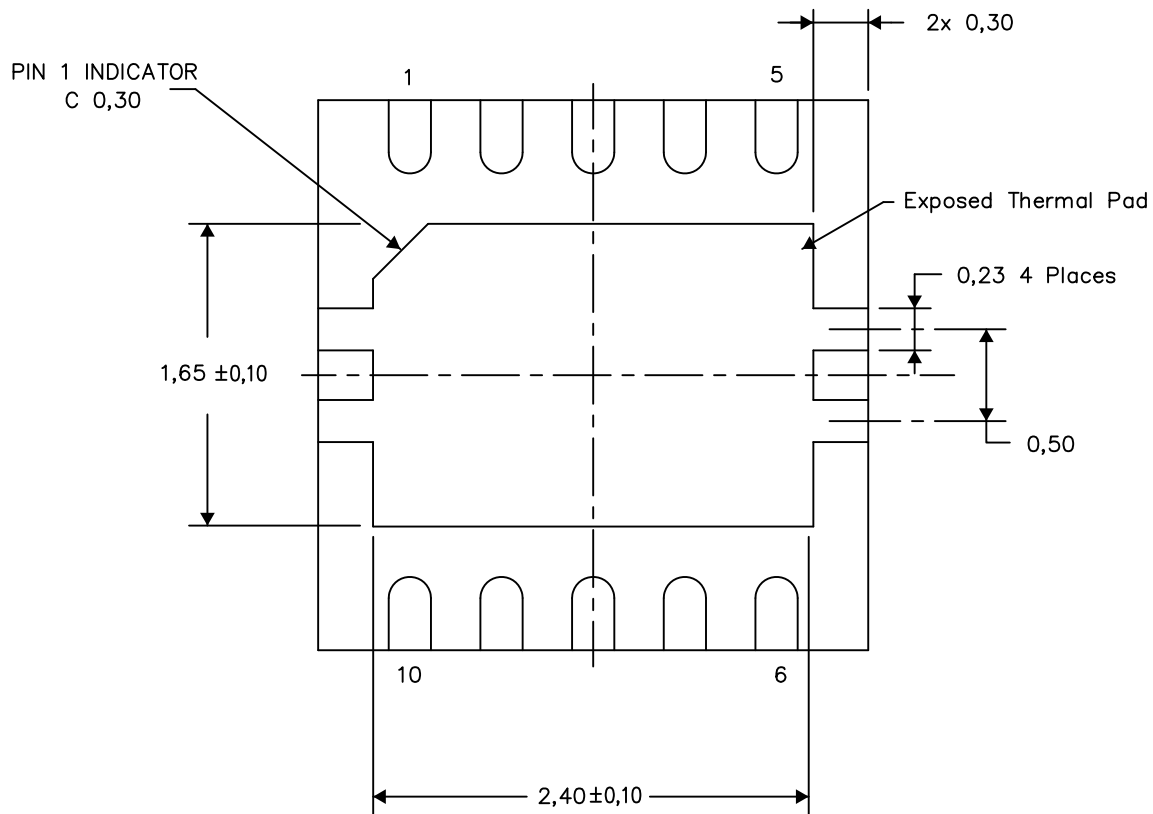

Bottom View

Exposed Thermal Pad Dimensions

4206565-3/Y 08/15

NOTE: A. All linear dimensions are in millimeters

DRC (S-PVSON-N10)

PLASTIC SMALL OUTLINE NO-LEAD

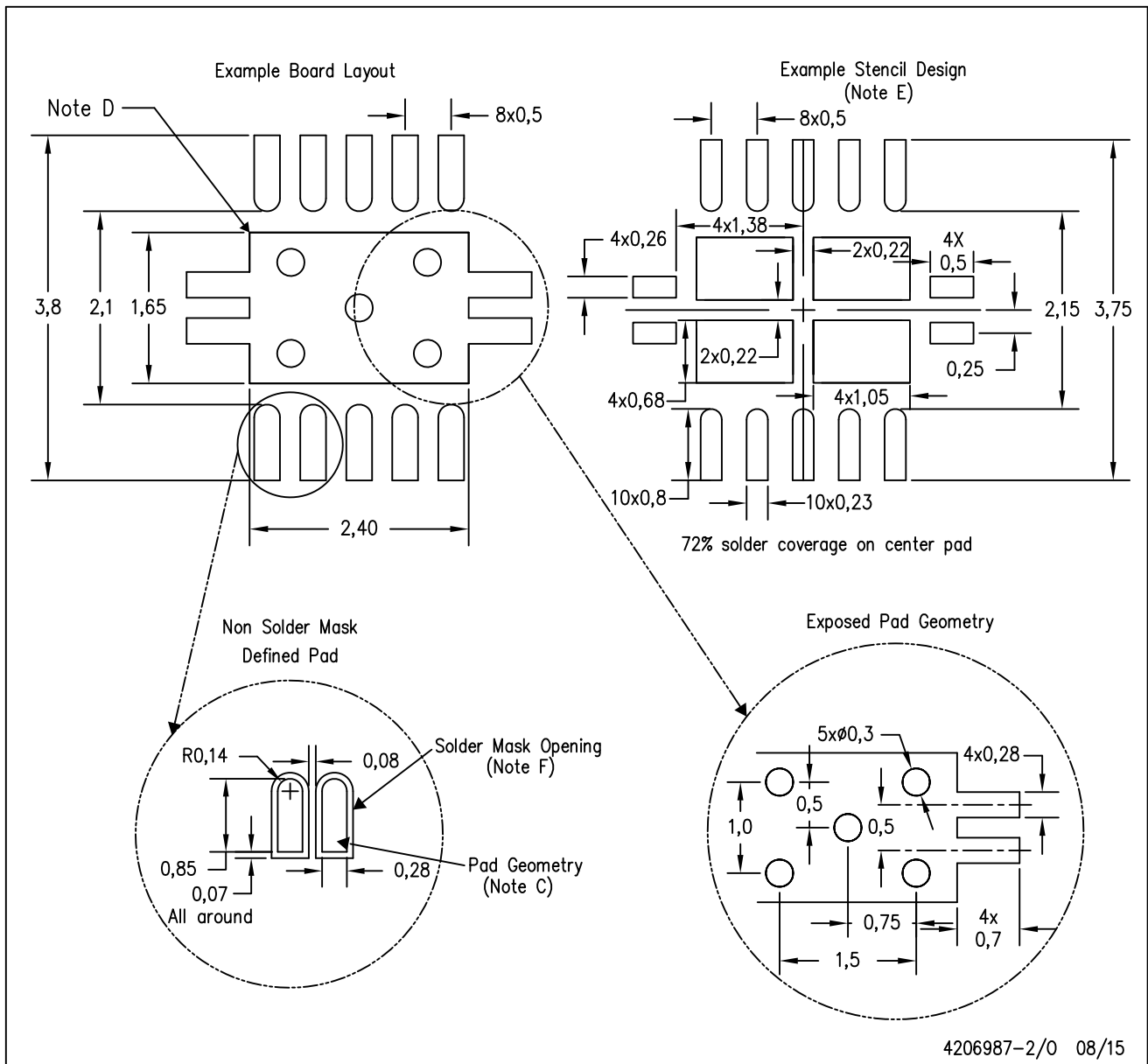

- NOTES:
- All linear dimensions are in millimeters.
 - This drawing is subject to change without notice.
 - Publication IPC-7351 is recommended for alternate designs.
 - This package is designed to be soldered to a thermal pad on the board. Refer to Application Note, Quad Flat-Pack Packages, Texas Instruments Literature No. SLUA271, and also the Product Data Sheets for specific thermal information, via requirements, and recommended board layout. These documents are available at www.ti.com <<http://www.ti.com>>.
 - Laser cutting apertures with trapezoidal walls and also rounding corners will offer better paste release. Customers should contact their board assembly site for stencil design recommendations. Refer to IPC 7525 for stencil design considerations.
 - Customers should contact their board fabrication site for minimum solder mask web tolerances between signal pads.

YZP (R-XBGA-N10)

(CUSTOM) DIE-SIZE BALL GRID ARRAY

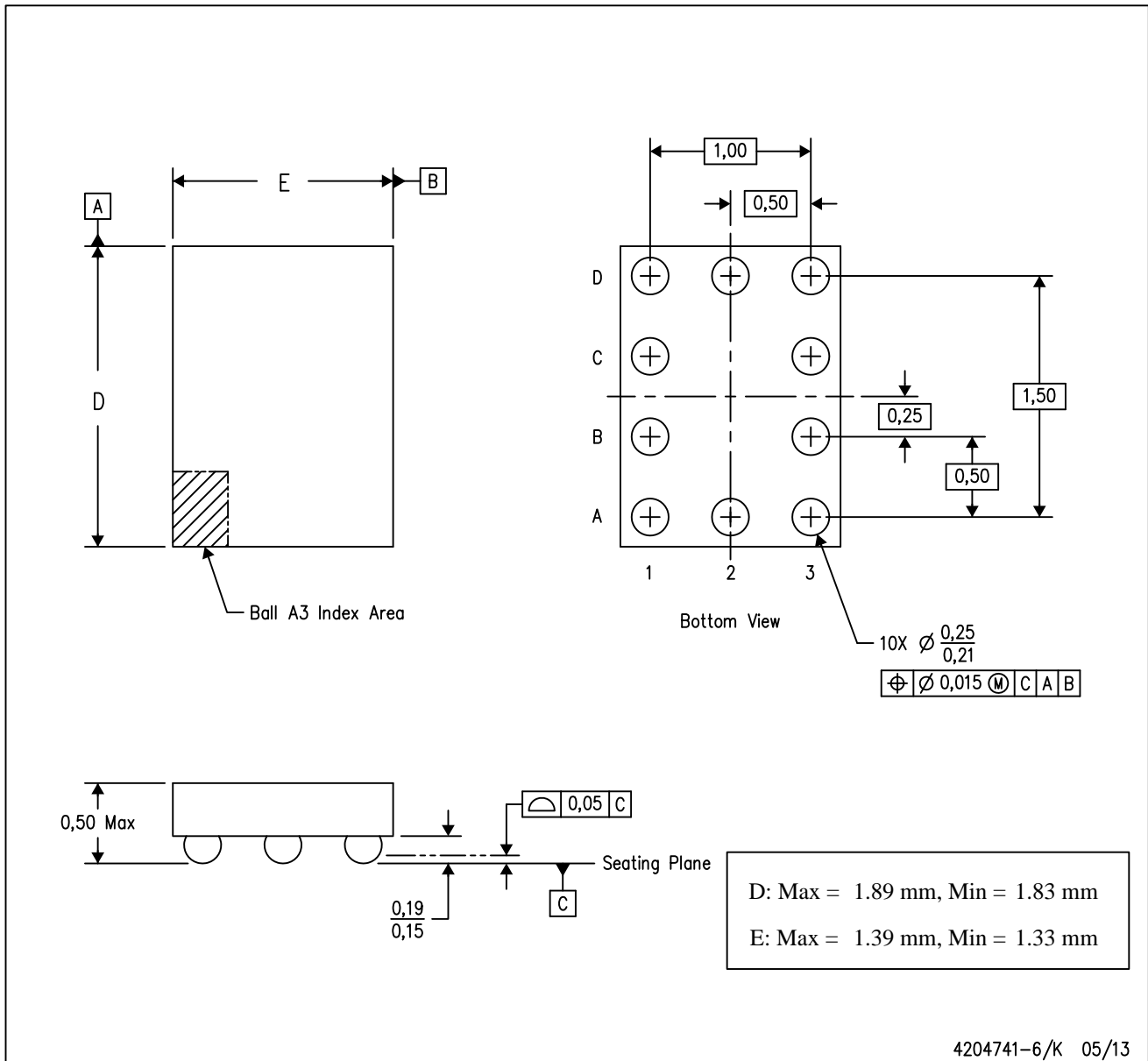

- NOTES:
- A. All linear dimensions are in millimeters. Dimensioning and tolerancing per ASME Y14.5M-1994.
 - B. This drawing is subject to change without notice.
 - C. NanoFree™ package configuration.

NanoFree is a trademark of Texas Instruments.

IMPORTANT NOTICE

Texas Instruments Incorporated and its subsidiaries (TI) reserve the right to make corrections, enhancements, improvements and other changes to its semiconductor products and services per JESD46, latest issue, and to discontinue any product or service per JESD48, latest issue. Buyers should obtain the latest relevant information before placing orders and should verify that such information is current and complete. All semiconductor products (also referred to herein as "components") are sold subject to TI's terms and conditions of sale supplied at the time of order acknowledgment.

TI warrants performance of its components to the specifications applicable at the time of sale, in accordance with the warranty in TI's terms and conditions of sale of semiconductor products. Testing and other quality control techniques are used to the extent TI deems necessary to support this warranty. Except where mandated by applicable law, testing of all parameters of each component is not necessarily performed.

TI assumes no liability for applications assistance or the design of Buyers' products. Buyers are responsible for their products and applications using TI components. To minimize the risks associated with Buyers' products and applications, Buyers should provide adequate design and operating safeguards.

TI does not warrant or represent that any license, either express or implied, is granted under any patent right, copyright, mask work right, or other intellectual property right relating to any combination, machine, or process in which TI components or services are used. Information published by TI regarding third-party products or services does not constitute a license to use such products or services or a warranty or endorsement thereof. Use of such information may require a license from a third party under the patents or other intellectual property of the third party, or a license from TI under the patents or other intellectual property of TI.

Reproduction of significant portions of TI information in TI data books or data sheets is permissible only if reproduction is without alteration and is accompanied by all associated warranties, conditions, limitations, and notices. TI is not responsible or liable for such altered documentation. Information of third parties may be subject to additional restrictions.

Resale of TI components or services with statements different from or beyond the parameters stated by TI for that component or service voids all express and any implied warranties for the associated TI component or service and is an unfair and deceptive business practice. TI is not responsible or liable for any such statements.

Buyer acknowledges and agrees that it is solely responsible for compliance with all legal, regulatory and safety-related requirements concerning its products, and any use of TI components in its applications, notwithstanding any applications-related information or support that may be provided by TI. Buyer represents and agrees that it has all the necessary expertise to create and implement safeguards which anticipate dangerous consequences of failures, monitor failures and their consequences, lessen the likelihood of failures that might cause harm and take appropriate remedial actions. Buyer will fully indemnify TI and its representatives against any damages arising out of the use of any TI components in safety-critical applications.

In some cases, TI components may be promoted specifically to facilitate safety-related applications. With such components, TI's goal is to help enable customers to design and create their own end-product solutions that meet applicable functional safety standards and requirements. Nonetheless, such components are subject to these terms.

No TI components are authorized for use in FDA Class III (or similar life-critical medical equipment) unless authorized officers of the parties have executed a special agreement specifically governing such use.

Only those TI components which TI has specifically designated as military grade or "enhanced plastic" are designed and intended for use in military/aerospace applications or environments. Buyer acknowledges and agrees that any military or aerospace use of TI components which have **not** been so designated is solely at the Buyer's risk, and that Buyer is solely responsible for compliance with all legal and regulatory requirements in connection with such use.

TI has specifically designated certain components as meeting ISO/TS16949 requirements, mainly for automotive use. In any case of use of non-designated products, TI will not be responsible for any failure to meet ISO/TS16949.

Products

Audio	www.ti.com/audio
Amplifiers	amplifier.ti.com
Data Converters	dataconverter.ti.com
DLP® Products	www.dlp.com
DSP	dsp.ti.com
Clocks and Timers	www.ti.com/clocks
Interface	interface.ti.com
Logic	logic.ti.com
Power Mgmt	power.ti.com
Microcontrollers	microcontroller.ti.com
RFID	www.ti-rfid.com
OMAP Applications Processors	www.ti.com/omap
Wireless Connectivity	www.ti.com/wirelessconnectivity

Applications

Automotive and Transportation	www.ti.com/automotive
Communications and Telecom	www.ti.com/communications
Computers and Peripherals	www.ti.com/computers
Consumer Electronics	www.ti.com/consumer-apps
Energy and Lighting	www.ti.com/energy
Industrial	www.ti.com/industrial
Medical	www.ti.com/medical
Security	www.ti.com/security
Space, Avionics and Defense	www.ti.com/space-avionics-defense
Video and Imaging	www.ti.com/video

TI E2E Community

e2e.ti.com